

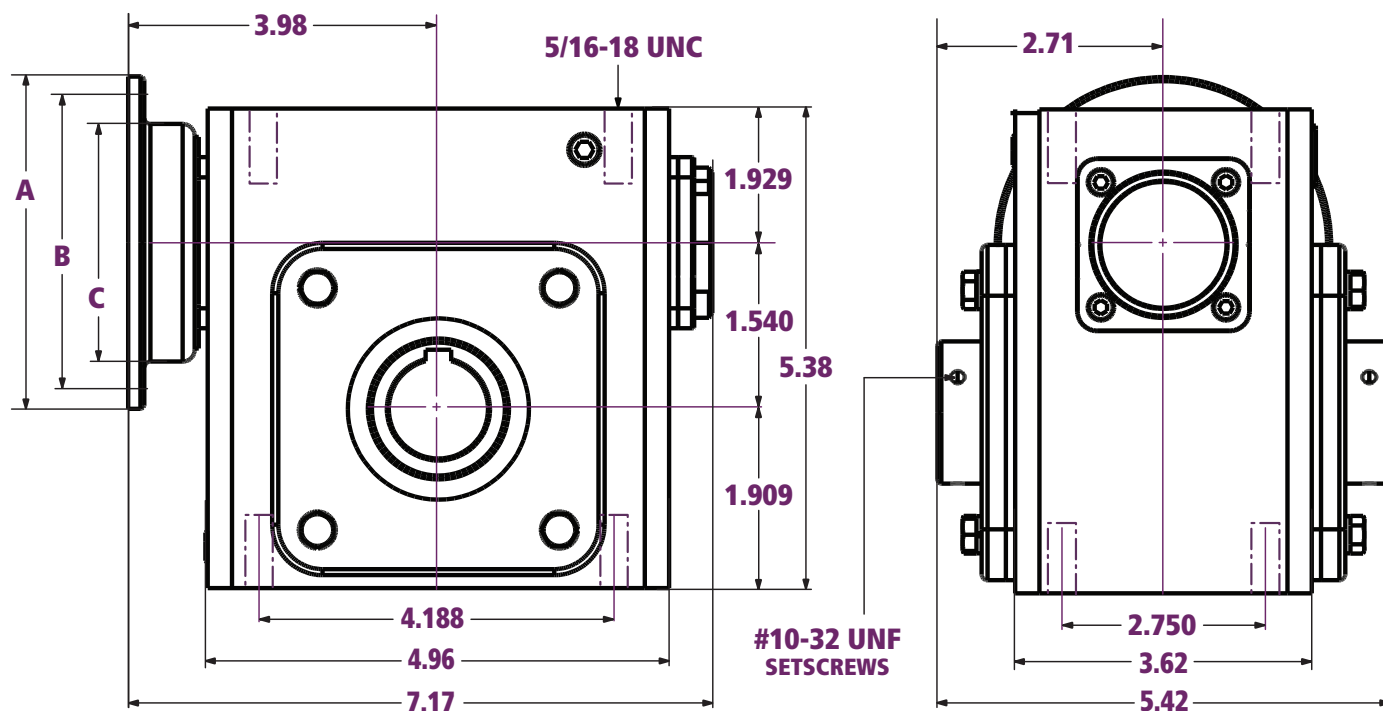

XH154 Dimensions

All dimensions listed in inches



Motor Options & Dimensions (in)

NEMA Frame	Motor Shaft Dia. (in)	A	B	C
		OD Flange	Bolt Circle	Pilot Bore
56C	0.625	6.50	5.88	4.5

Output Bushing Kits

Output Bushing Diameter (in)
—

Output Hollow Bore

Output Keyway (in)	Output Bore (in)
3/16 x 3/32	0.625

Ratios

Nominal Ratios	Exact Ratios
5:1	5.0:1
10:1	10.0:1
15:1	15.0:1
20:1	20.0:1
30:1	30.0:1
40:1	40.0:1
50:1	50.0:1
60:1	60.0:1

Efficiency

Nominal Ratios	Efficiency (%)
5:1	≈ 92
10:1	≈ 88
15:1	≈ 86
20:1	≈ 81
30:1	≈ 74
40:1	≈ 68
50:1	≈ 66
60:1	≈ 59

Specifications

Center Distance (in)	Weight (lbs)	Est. Oil Fill Amount* (oz)
1.540	15.4	11.5

*For Position 1.

XH154 Accessories

and X154 Base Kit Dimensions

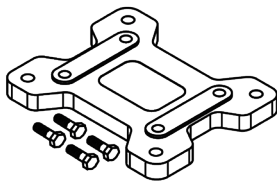
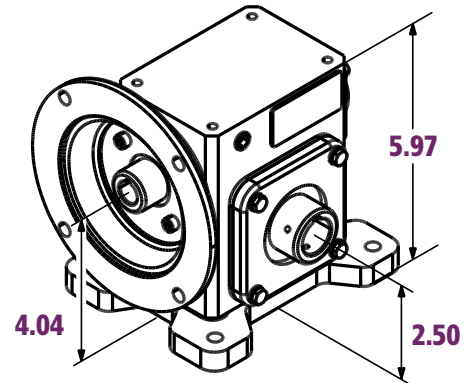
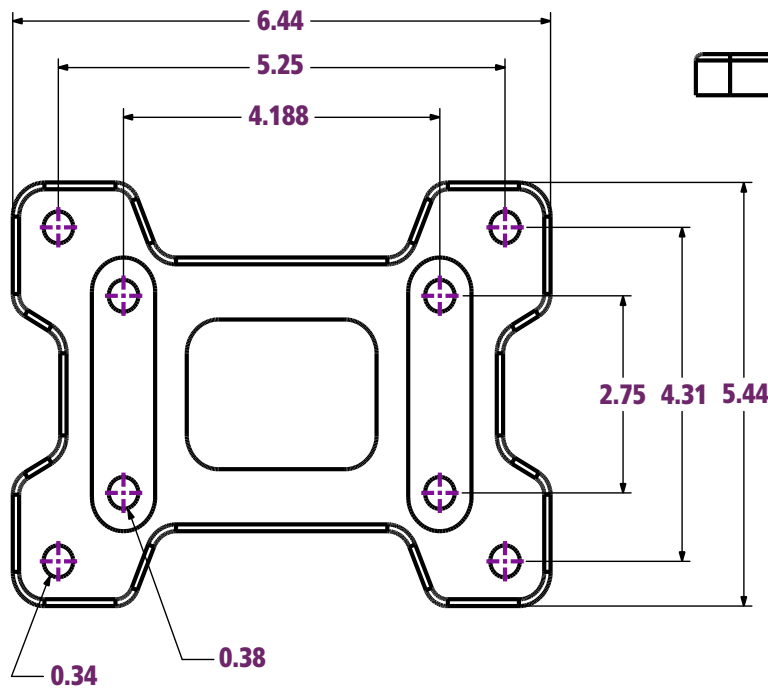

Foot Mounted Base Kit

XBK154

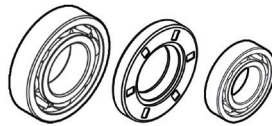

Component Repair Kit

XHRK154

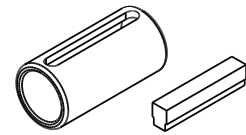

Input Quill Adapter Option

None

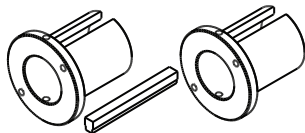

Output Bushing Kits*

Not Applicable

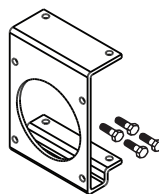

Output Bracket Kit*

XOB154

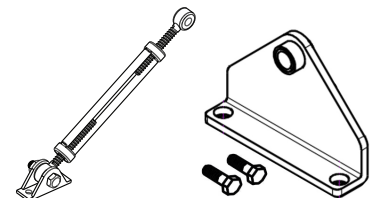

Torque Arm Kit*

XTA154

*Made to order.